



The UL-HZ2503 Hazard Tape is designed to ensure visibility of obstacles in escape routes for compliance with NFPA 101 Life Safety Code (NFPA 101) and International Fire Code (IFC). The Hazard Tape will be effective in all light conditions including failure of the main lighting.

COMPLIANCE

UL Listed and NFPA 101 and IFC compliant. Can be used in Performance Solutions to meet the requirements of any performance based building codes.

Brightness - High visibility in light or dark conditions meets UL 1994.

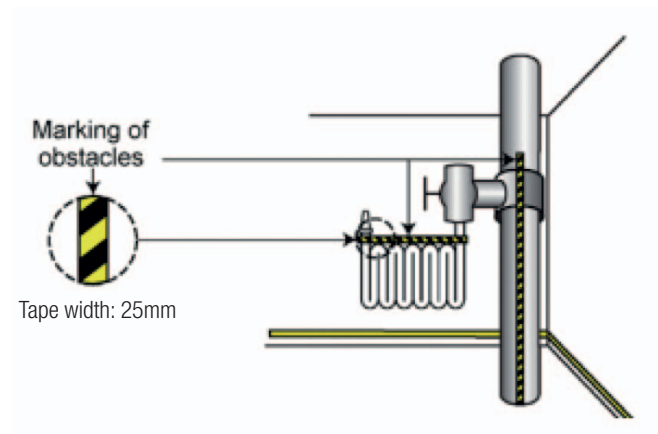

SUPPLY

The product comprises one roll of photoluminescent tape and one roll of adhesive tape and is available in rolls of 3 metres.

COMPOSITION

Manufactured using high quality vinyl, the UL-HZ2503 Hazard Tape includes a separate adhesive tape which is long lasting and provides a superior bond to a variety of surfaces.

INSTALLATION

Installation is a simple process using supplied adhesive tape.

UL-HZ2503 25mm wide x 3m roll

Contact

Ecoglo Fire Protection Product Trading

Address: 36-C Gloria Street, Barangay San Carlos, Binangonan Rizal 1940, Philippines

Office: +632-8802-4760

Cell: +63917-514-6803

+63968-356-4773

Email: keith.phillips@ecoglo.com

Web: www.ecoglo.ph www.EcogloAsia.com www.EcogloVenues.com